

3420 Fostoria Way Suite A-200
San Ramon, California 94583
Phone 925/973-0710
Phone 800/827-7940
Fax 925/973-0764

From the pioneers in dental air abrasion.

Prep Start[™]



OPERATORS MANUAL

Danville
MATERIALS 
INNOVATIVE DENTAL PRODUCTS

NOTICE

All rights reserved. No part of this manual may be reproduced or transmitted in any form or by any means without the express written consent of Danville Materials, Inc.

Danville Materials, Inc.
3420 Fostoria Way Suite A-200
San Ramon, CA 94583-1229  ⁰⁰⁴⁴

Phone: 925 973-0710
Fax: 925 973-0764

IMPORTANT INFORMATION TO BE READ BEFORE OPERATING THE SYSTEM

This manual should be carefully reviewed prior to use of the PrepStart. Misuse of the PrepStart may result in hazards to personnel, including injury or death. Misuse or failure to properly maintain the PrepStart will result in poor performance and shorten the unit life. The PrepStart is intended for professional use only.

EYE PROTECTION

Protective eye equipment should always be worn by patients and staff during air abrasive use. Loops and other optical and mechanical equipment must also be protected. Wash off particles from optics, do not rub them off.

OFF - SAFETY POSITION

Always switch the PrepStart off when not in use to prevent accidental activation. The pressure switch is located in the back of the PrepStart (down position is off) (see fig. 4.2). The pressure gauge will indicate pressure status.

RISK OF EMBOLISM

Pressurized air directed at gingiva or pulpal exposures can induce an air embolism. A rubber dam or other barrier is essential for procedures where direct or rebounding air and particles can contact the gingiva (such as class V).

RESPIRATORY PROTECTION

While aluminum oxide is rated as a “nuisance” dust, unnecessary inhalation of any particulate is undesirable. Persons with respiratory problems, such as asthma, should avoid exposure.

When a rubber dam is not used, the patient should be asked to hold his breath during the actual intervals of abrasion. A damp cloth is ideal to protect the patient’s eyes and nose, or goggles may be used. Aluminum oxide can be swallowed without harm. Standard surgery masks protect the staff. **Do not use on amalgam due to the resulting aerosolizing of mercury alloy.**

PRACTICE - EXTRACTED TEETH

Use of the PrepStart is very similar to a high speed handpiece. The primary difference being no tactile sense, necessitating a ‘cut and look’ technique. Dwelling too long in one spot can accidentally induce a pulpal intrusion. Practicing on extracted teeth is highly recommended. When confidence is gained, proceed to small class I & V restorations. Most report the technique is easy to learn.

RECOMMENDED ABRASIVES

It is recommended that only Danville 50 and 27 micron abrasives be used as they are dry, high purity alpha alumina and specially formulated for maximum performance. Other powders can result in poor performance or equipment damage, powders other than Alpha Alumina should never be used based upon health concerns. Abrasives readily absorb moisture from the air and become thickened which results in plugging. Keep abrasives tightly capped. Dry abrasive should flow like water. Moist abrasive will ‘avalanche’ when poured or even clump. Tan color abrasives will stain white surfaces. Never reuse spent powders. Both microns are ideal for all applications; 50 micron cuts slightly faster, 27 is considered by some to induce less sensitivity.

I.0 PREPSTART SETUP & USE

I.1 INSPECTION

1. Upon arrival inspect the PrepStart and components for possible shipping damage. Report damage immediately to the shipper and send a copy of your report to your dealer or Danville.
2. Inventory all components.

I.2 AIR SOURCE

Only clean, dry air is required for operation. The filtration / desiccation system in the PrepStart can be overwhelmed by excessive moisture content resulting in poor performance. Adequate filtration and water traps are essential.

Supply pressures of: 80 psi (5.3 bars) is minimum. 100 psi (6.6 bars) is ideal. 125 psi (8.3 bars) is maximum. If necessary, a technician can normally adjust the compressor's operating pressure range to a higher level. An increase in compressor pressure should not affect other equipment as each cart is separately regulated. Another alternative is the *Power Plus™* pressure booster accessory that will double pressure up to 125 psi (8.3 bars).

Adequate volume of air flow is as equally important as static pressure. Inadequate flow volume will result in a significant pressure drop when in use.

Test: Set the PrepStart at, or close to, 100 psi (6.6 bars). Install a .019" tip. Watch the pressure gauge when the foot pedal is activated. No more than a few pounds (1/10 bars) of pressure drop should be noticed.

If a far greater pressure drop is noticed, the air lines from the compressor may be undersized or there are other flow constrictions. Use of the *Power Plus™* air booster will only increase the problem as it also consumes air during use, greatly increasing the flow demands of the PrepStart alone. New tubing runs can easily be installed if necessary, using flexible polyethylene.

A female quick disconnect kit is provided for installation on the **full pressure airline** located in the junction box or cart (the same disconnect as supplied for the Microetcher). Instructions are included with the disconnect kit. **Label similar disconnects that are for water to avoid accidental connection!** Connect the PrepStart to the air source using the double ended male disconnect air line provided.

I.3 FOOT PEDAL CONTROL

Connect the foot pedal to the back of the PrepStart, (see Fig. 4.2) color-coding of the connectors must be observed or leaking will result. Operation of the pedal should produce a crisp on/off abrasive flow.

I.4 ABRASIVE FILL

Maintaining proper abrasive fill is essential for good performance. Low abrasive levels in chamber (<1/3 full) will result in low powder flow and poor cutting.

1. Flip the switch down in back of PrepStart (see Fig. 4.2) to shut off the air and vent the system. The pressure gauge should read zero. Unscrew the reservoir cap.
2. Check the brass cap inside jar for correct micron size before adding powder. This cap tunes the PrepStart for the abrasive size and is marked: 27 or 50.
3. Fill up to, but not over, the brass cap, to prevent excessive flow.
4. Clean the threads before replacing the reservoir cap. The cap should be screwed down, sliding over the primary o-ring, until it seats against the secondary filter inside the lid. Do not over tighten.
(Powder removal is accomplished by turning the PrepStart upside down.)

I.5 HAND PIECE

Screw the gray hand piece line into the port in the lower front of the PrepStart, and connect to the hand piece body. Connect the selected nozzle to the hand piece. The hand piece will 'click in' magnetically to the top of the PrepStart.

I.6 NOZZLE SELECTION

Two nozzles are included .015" and .019" @ 80 deg. Other sizes and angles are available.

- .015" for highly minimal preps. Slow cutting
- .019" for general use.
- .026" highly aggressive cutting, broad surface etching.

I.7 PRESSURE SETTINGS

The pressure is turned on/off by the toggle switch in the back of the PrepStart. The pressure is adjusted by turning the lower knob (see Fig. 4.1), on the front panel, and can be observed on the gauge. **Cut speeds increase dramatically with pressure.** Increasing pressure from 80 psi to 100 psi will almost double the cutting speed. However lower pressures, of 80 psi or less will greatly reduce sensitivity in dentin. Often, higher pressure is used to rapidly cut through the enamel, then reduced when in contact with dentin. If sensitivity persists, use of a lower pressure is advised.

- 110 psi (7.3 bars) = Suggested maximum
- 80 psi (5.3 bars) = Ideal, low sensitivity cutting
- 40 psi (2.7 bars) = Light cutting, diagnostic etch & aggressive stain removal

I.8 ABRASIVE SETTINGS (See Fig. 4.1)

The PrepStart mixes abrasive depending upon the volume of airflow, like a carburetor. Therefore, the abrasive flow rate is automatically adjusted as air flow rates change (tip size or pressure changes). Adjustments are to reduce cut speed from a maximum cut to a light etch. Middle settings allow cutting with reduced abrasive use.

- Full on to $\frac{3}{4}$ on = Normal cutting
- Full off = Light cutting, diagnostic etch & aggressive stain removal

Optional abrasive flow setting - In some situations an even lower flow of abrasive may be required. For decreasing the abrasive flow below the standards settings described above, the following directions must be followed:

1. Do the following to remove the cover from unit:
 - Remove the four screws from bottom of base that are located in the deep holes on the bottom of the unit. Do not remove feet screws and/or feet.
 - Remove the cap and two o-rings located on the jar cylinder.
 - Tilt the Back end of cover up until cover is removed from the bracket on front panel.
2. Find the white plastic pinch clamp located next to the pinch cylinder, between the pinch cylinder and the outside of the unit.
3. Open the clamp to a full open position. *The unit is now at its lowest powder rate setting with the clamp fully open.*
4. Replace cover.

I.9 EVACUATION

Abrasives and debris are collected by aspiration. High speed suction in most dentists office is adequate. The efficiency of collection improves dramatically as the assistant becomes accustomed to seeking the moving 'cone of dispersion'. No damage to house suction has been reported but more frequent cleaning is essential.

- Hold suction about 8" away and move to seek debris plume.
- The tissues of the mouth trap most debris when a rubber dam is not used.
- Place damp gauze in the back of the rubber dam to aid in collection.

For chair-side use, a dust cabinet, such as the Danville Microcab™ or Macrocab™ is suggested.

2.0 OPERATING INSTRUCTIONS

2.1 SUGGESTED PATIENT ORIENTATION & SELECTION

- Pediatric patients respond well to first being shown a blast of air, or air abrasive, on their hand, and then being told that the same painless spray will be used in the treatment.
- For adults, a description of the 'high tech' nature of the treatment not only instills patient confidence, but reinforces the uniqueness of your practice.
- Adult patient selection is the first step: patients that respond poorly to the air syringe are often not good candidates.
- Lesions that are suspected as being very deep may involve a higher level of patient discomfort.

2.2 TECHNIQUE OF USE

Tooth reduction:

1. Hold the nozzle at about a 60° angle up from the surface (a slight angle from perpendicular). Angling the stream reduces sensitivity in dentin.
2. Hold the tip 1-2mm from the surface. Move in slow, even passes.
3. Inspect cut result after every few seconds.

Surface etching & aggressive stain removal:

1. Hold tip 5-10mm away from surface.
2. Dwelling will result in excessive surface reduction of the tooth.
3. Use slow sweeps on metals, ceramics and composites until surface is clean and evenly etched.

2.3 INDICATIONS FOR USE

The PrepStart system is intended for the following applications:

- Cavity preparations for smaller composite restorations. Class I to VI.
- Removal of composites, acrylic and other resin restoratives.
- Pit and fissure prep.
- Stain removal to reveal lesions.
- Conservative preparation of incipient lesions.
- Endonic access through porcelain crowns.
- Etching for all metals, composites, acrylics and amalgam for a superior bond.
- Etching porcelain where hydrofluoric acid use is not advisable.
- Aggressive stain removal. Removal of amalgam tattoos.
- Enhancing bond to tooth structure. Acid etch after air abrasion has been shown to be superior to an acid etch alone.

2.4 CONTRAINDICATIONS

- Removal of amalgams with any air abrasion device is not recommended. Mercury laden dust is generated without the capturing water spray.
- Clinical use which is not in accordance with the indications listed in this manual should be avoided.
- In all applications, clinical use must be subject to the discretion of the dental professional.

2.5 ANESTHESIA

Air abrasion has been used clinically for anesthesia free dentistry for over 10 years with great reported effectiveness. Most users report few patients preferring an injection. A high effectiveness rate is a combination of patient selection, verbal preparation and user technique. Lower pressures and angling of the nozzle are key factors. Rubber dam clamp discomfort can be controlled with use of lidocaine patches.

Factors associated with air abrasion's low sensitivity:

- No heat or vibration (as are generated by the high speed handpiece).
- Tubules are closed by the abrasive particles compacting the dentin.
- The psychological benefits of not hearing the whine of the high speed.

2.6 STERILIZATION & DISINFECTION

Warning: The handpiece and nozzle must be sterilized prior to each use. The hose assembly and other elements that come in close proximity to patients should be sheathed or wiped down in accordance with standard disinfecting procedures.

1. Place handpiece, nozzle with o-rings, free of abrasive and other debris, in a sterilization pouch.
2. Autoclave in saturated steam, 132°C, 27.4 psi for 15 min.
3. Allow cooling for 30 min. prior to handling.

3.0 MAINTENANCE & TROUBLE SHOOTING

3.1 MAINTENANCE

Inspection (A-D) after every 1 lb. (500g) of abrasive use:

- A. Desiccant chamber:** Inspect the desiccant granules through the view window located in the bottom of the unit (see Fig. 4.3). The blue indicator granules will turn white when contaminated. Replace with new desiccant if necessary. Use the Service Wrench to unscrew and to replace the cap. Clean 'o' ring and threads before replacing. Do not over tighten.
- B. Abrasive jar:** Clean threads and o-rings. Lightly lubricate o-rings with petroleum gel (see Fig. 4.1).
- C. Waste Powder Chamber:** Unscrew the Abrasive Recovery Cap (see Fig. 4.3) using the Service Wrench. Remove any abrasive from the chamber, clean the threads and replace the cap. Do not over tighten.
- D. Moisture trap:** Very minimal, or no moisture should be found. While the PrepStart is pressurized and held in a horizontal position, depress the trap stem (see Fig. 4.3) with a finger tip: compressed air, and any moisture will be expelled. If more than a few drops of moisture are found, additional water traps and filtration, may be necessary.

Inspect tips monthly or after 100 uses

Worn nozzles cut with greatly reduced efficiency. Uneven erosion of the nozzle bore reduces particle acceleration and increases the angle of spray. Replace nozzles when enlargement of the bore is noticed. Normal life is 100 to 200 uses. In extreme cases of wear, the stream will cut through the side of the carbide tip or through the stainless tube, which is a safety concern. The bore can also be gauged by placing tapered endodontic files into the nozzle bore and observing how deeply it will easily pass: .015" Nozzles - use a # 15 file; .019" - use a # 20 file; .026" - use a #55 endodontic file: when most of the taper passes through the bore the nozzle should be replaced.

Inspect Abrasive Jar O-Rings Monthly

Replace worn, damaged or leaky o-rings. Small leaks will result in abrasive cutting the jar o-rings. Cleaning abrasive from the threads before replacing the cap will greatly extend o-ring life.

Inspect pinch valve performance after every 6 months of use:

Pinch valve performance: The pinch valve controls the output stream of air / abrasive and wears with use. A worn pinch valve tube will not shut off completely and will allow a small amount of air to continue to escape. A badly worn pinch valve tube can even cause internal abrasive leaks that will prevent use. Under normal use the PrepStart pinch valve tube will last a minimum of one year.

Test: Place the nozzle tip in a glass of water. A leak will cause a bubble to form every second. A large leak will cause a constant stream of bubbles and signals the need to renew the pinch valve tubes.

3.2 TROUBLE SHOOTING

Trouble Shooting	
Problem	Solution
Plugged nozzle	Blow air backwards into the disconnected nozzle.
Slow cutting performance	<p>Slow cutting is caused by: weak abrasive flow, or low pressure and/or a nozzle that is small size, or worn out. A microscope slide is included for a standardized cut test.</p> <p>Test: With a .019 tip held perpendicular at 1mm, with maximum abrasive flow and 100 psi, the slide should be pierced in 3 to 5 sec.</p> <ol style="list-style-type: none"> 1. Check the abrasive fill and for the correct brass tuning cap inside jar. 2. Check the pressure setting: higher pressure dramatically increases the cut speed. 3. When the PrepStart is activated the pressure gauge should not drop more than a few psi (1/10 bar). See 'Air Source' (Sect. 1.2). 4. Check nozzle size; (.015" nozzles will cut slow). 5. Set powder control to maximum (clockwise). 6. Check for weak powder flow (see weak powder flow below).
Abrasive flow does not shut off immediately	<ol style="list-style-type: none"> 1. Empty waste powder chamber. 2. Pinch valve or waste powder chamber filters may need service.
Excessive powder flow	<ol style="list-style-type: none"> 1. Ensure the abrasive tuning cap matches the size of abrasive used (27or 50 micron). 2. Empty the waste powder chamber. 3. Ensure abrasive level in powder jar is below tuning cap.
Internal air leak	Check for excessive pressure. Pressures above 125 psi (8.3 bars) will be automatically vented by an internal safety valve.
Weak powder flow	<p>Weak abrasive flow will greatly reduce the cutting efficiency. The PrepStart is tuned to use about 5gm/ min. at 100 psi (6.7 bars) at the maximum powder setting. The abrasive stream is most easily viewed when sprayed across a dark background with good lighting. The spray should appear light but clearly defined. Weak abrasive flow can be caused by:</p> <ol style="list-style-type: none"> 1. Low powder in the abrasive jar. 2. Incorrect abrasive tuning cap. 3. Low abrasive setting or moist abrasive. 4. Plugged jar metering holes result from moisture contamination, and prevents abrasive from being picked up (see: Recommended Abrasives pg. 1). <p><i>(Dump out moist abrasive. Inspect the bottom of the jar for abrasive collecting around the inner column. A ring of more than 4mm of abrasive will block the metering holes. Remove the abrasive with an explorer.)</i></p>

3.3 PINCH TUBE RENEWAL

The pinch tubes can be easily renewed in the office provided it has not ruptured.

1. Depressurize and disconnect from air.
2. Remove the abrasive jar cap, the abrasive, and the upper o-ring on the jar.
3. Remove the four Philips head screws in the underside of the PrepStart (see Fig. 4.3).
4. Lift the top cover off, tilting the rear of the cover up first.
5. The pinch valve is an aluminum cylinder near the outlet port (see Fig. 4.4). Two black plastic tubes passing through (see Fig. 4.3) the cylinder are the pinch tubes. The pinch spot is renewed by pulling both tubes with pliers, about 7mm toward the rear of unit.
6. Reassemble in reverse of above procedure.

After several 'renewals' the pinch tubing will have to be replaced at a service center. Please note that pinch valve service should be performed at an authorized service center as opening the cabinet will void the warranty.

3.4 RETURNS & SHIPMENTS

Prior to the return of a system, or any portion thereof, you should contact your dealer for servicing. Your full service dealer is equipped to handle most repairs of the PrepStart. Should your unit require a return to the factory, your dealer will arrange this for you. Shipment of a unit to the factory without the proper return authorization may result in a returned shipment. If you have any questions about these procedures, please contact Danville at 1-800-827-7940 or fax to 1-925-973-0764.

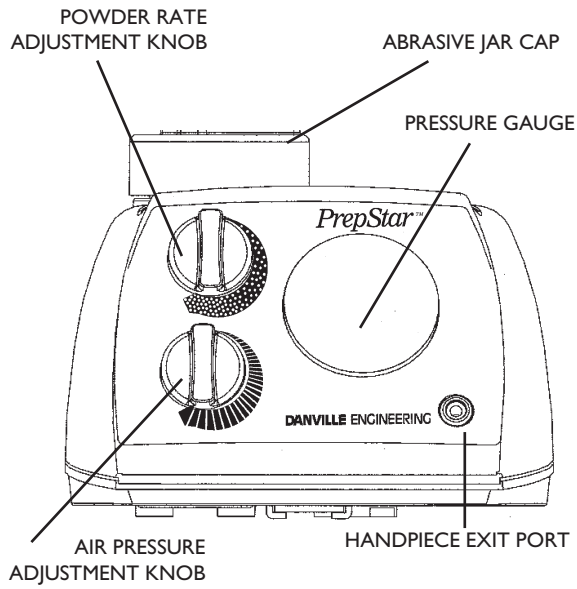

Figure 4.1
Front View of PrepStart

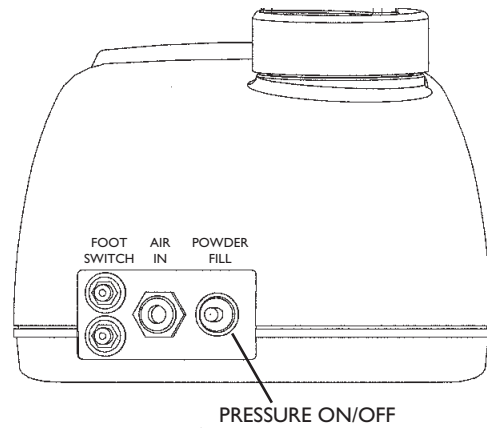

Figure 4.2
Rear View of PrepStart

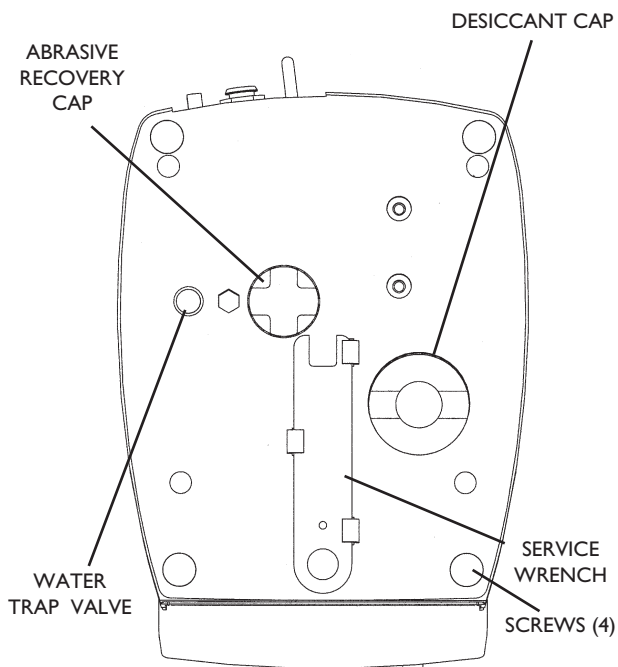

Figure 4.3
Bottom View of PrepStart

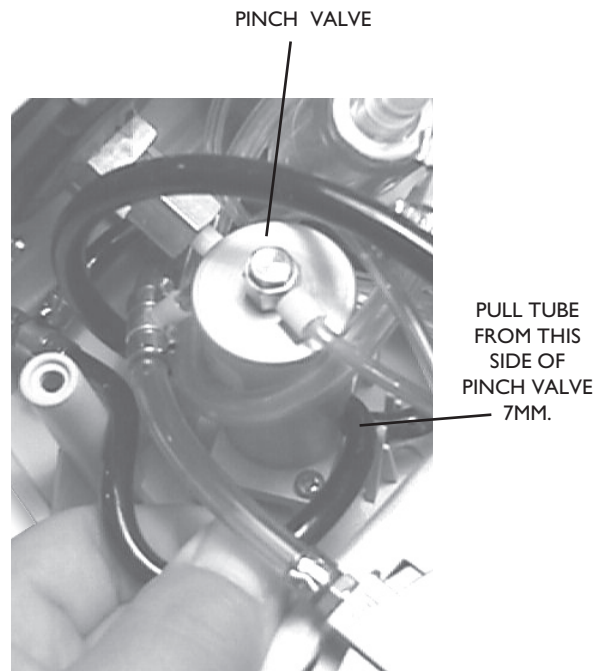

Figure 4.4
Inside of PrepStart

